

CUSTOMER APPROVED

BY: \_\_\_\_\_

DATE: \_\_\_\_\_

TITLE: \_\_\_\_\_

THE SIGNATURE ABOVE INDICATES THE FINAL APPROVAL FOR THE MATERIAL DISCRIBED AND RELEASE TO MANUFACTURING. THE PURHASER ACKNOWLEDGES THAT THESE PRODUCTS ARE OF SPECIAL MANUFACTURE AND NOT SUBJECT TO CANCELLATION OR RETURN.

(DH) DUMP HEIGHT	(OC) OVERHEAD CLEARANCE	(FH) FRAME HEIGHT	STATIONARY MODEL No.	PORTABLE MODEL No.
72"	128"	88"	7692401	7692402
84"	140"	100"	7692501	7692502
96"	152"	112"	7692601	7692602
108"	164"	124"	7692701	7692702
120"	176"	136"	7692801	7692802

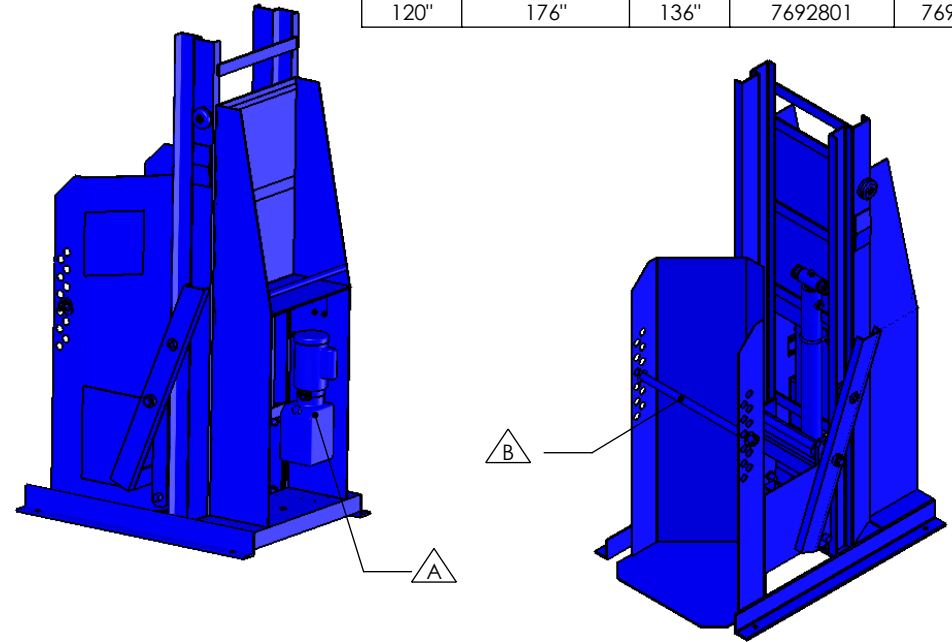
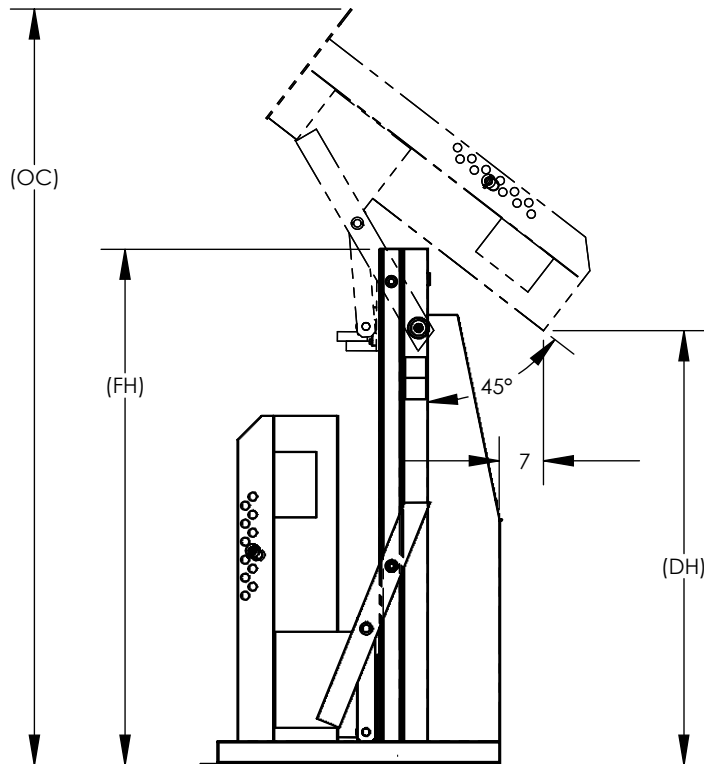
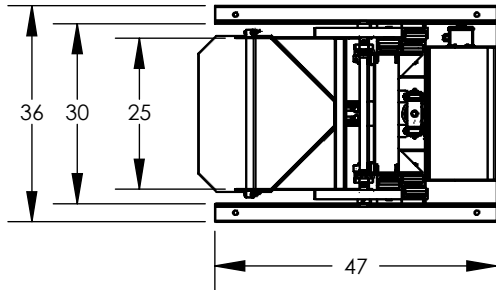

NOTES:

**A** : NEMA 12 1/60/115V POWER UNIT (1HP MOTOR) WITH PU/GD "DEAD-MAN" CONTROLS

**B** : ADJUSTABLE HOLD DOWN BAR

PAINTED BLUE ENAMEL

1500 LBS MAX CAPACITY

DRAWING AND CHART DEPICT STANDARD DUMPERS. OPTIONS NOT SHOWN ON THIS DRAWING ARE LISTED ON YOUR QUOTATION. PLEASE DISCUSS WITH YOUR SALES CONTACT, ANY CHANGES OR OMITTED ITEMS YOU REQUIRE, SO THEY BE ADDED TO YOUR QUOTATION. A DETAILED APPROVAL OF CUSTOM DUMPER WITH MODIFICATIONS WILL BE SUPPLIED AFTER RECEIPT OF ORDER.

**DUMPERS ARE NOT SUBJECT TO CANCELLATION OR RETURN**

*THE INFORMATION CONTAINED IN THIS DRAWING IS THE SOLE PROPERTY OF THE MANUFACTURER. ANY REPRODUCTION IN PART OR AS A WHOLE WITHOUT THE WRITTEN PERMISSION OF THE MANUFACTURER IS PROHIBITED.*



HERCULES IND. 770 S. 70TH ST. MILWAUKEE, WI 53214  
PH: 1-800-251-1234

**TITLE:** DRUM DUMPER/HI LEVEL

**PART NO.** SEE CHART

REV: \_\_\_\_\_ DATE \_\_\_\_\_ SHEET 1 OF 1