

CUSTOMER APPROVED

BY: _____

DATE: _____

TITLE: _____

THE SIGNATURE ABOVE INDICATES THE FINAL APPROVAL FOR THE MATERIAL DISCRIBED AND RELEASE TO MANUFACTURING. THE PURHASER ACKNOWLEDGES THAT THESE PRODUCTS ARE OF SPECIAL MANUFACTURE AND NOT SUBJECT TO CANCELLATION OR RETURN.

(DH)	(CL)	(CW)	(CR)	(CH)	(FW)	(HC)	(OC)	STOCK No.		
DUMP HEIGHT	CHUTE LENGTH	CHUTE WIDTH	CHUTE REACH	CHUTE HEIGHT	FRAME WIDTH	HORIZONTAL CLEARANCE	OVERHEAD CLEARANCE	2000 lb	4000 lb	6000 lb
36"	36"	36"	12-1/2"	66"	51"	72"	111"	74353	74543	74592
36"	48"	51"	12-1/2"	66"	66"	81"	119"	74438	74547	74599
48"	36"	36"	10"	72"	51"	79"	127"	74739	74743	74593
48"	48"	51"	10"	72"	66"	87"	135"	74494	74548	74601
60"	36"	36"	5"	72"	51"	83"	138"	74433	74658	74594
60"	48"	51"	5"	72"	66"	91"	146"	74756	74535	74536
72"	36"	36"	5"	84"	51"	148"	150"	57108	*57109	*57110

* 72" DUMP HEIGHT MODELS IN 4000 lb and 6000 lb CAPACITIES HAVE CHUTE ELEVATED 12" OFF FLOOR. FORK TRUCK REQUIRED FOR LOADING

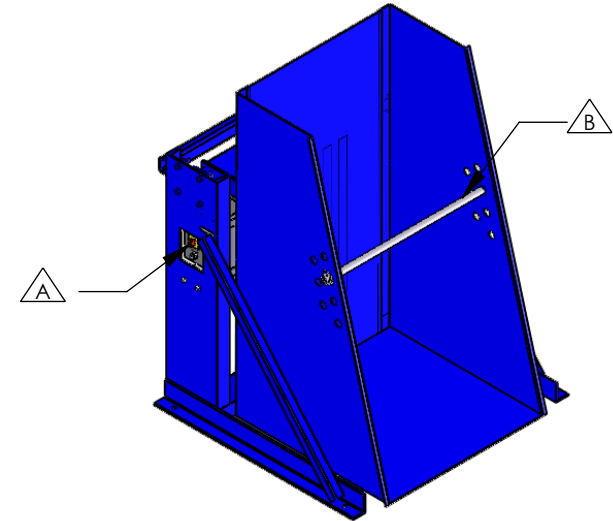
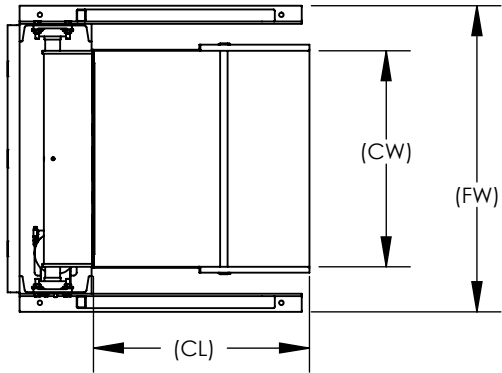

NOTES:

A NEMA12 3/60/460V POWER UNIT (2HP MOTOR) WITH PU/GD "DEADMAN" CONTROLS

B ADJUSTABLE HOLD DOWN BAR (30" - 42")

PAINTED BLUE ENAMEL

DRAWING AND CHART DEPICT STANDARD DUMPERS. OPTIONS NOT SHOWN ON THIS DRAWING ARE LISTED ON YOUR QUOTATION. PLEASE DISCUSS WITH YOUR SALES CONTACT, ANY CHANGES OR OMITTED ITEMS YOU REQUIRE, SO THEY BE ADDED TO YOUR QUOTATION. A DETAILED APPROVAL OF CUSTOM DUMPER WITH MODIFICATIONS WILL BE SUPPLIED AFTER RECEIPT OF ORDER.

DUMPERS ARE NOT SUBJECT TO CANCELLATION OR RETURN

THE INFORMATION CONTAINED IN THIS DRAWING IS THE SOLE PROPERTY OF THE MANUFACTURER. ANY REPRODUCTION IN PART OR AS A WHOLE WITHOUT THE WRITTEN PERMISSION OF THE MANUFACTURER IS PROHIBITED.



HERCULES IND. 770 S. 70TH ST. MILWAUKEE, WI 53214
PH: 1-800-251-1234

TITLE: BOX DUMPER

PART NO. SEE CHART

REV: A DATE SHEET 1 OF 1

